

# FPG2



### Family features:

- ▶ Double-hall sensor available
- ▶ Degree of protection: IP 53
- ▶ Operating mode: S2
- ▶ Direction of rotation: CCW/CW

	Part number	P <sub>n</sub> (Nominal power) W	I <sub>n</sub> (Nominal current) A	n <sub>n</sub> (Nominal speed) rpm	M <sub>n</sub> (Nominal torque) Nm	M <sub>a</sub> (Stall torque) Nm	Gear ratio	Signal	Side*	Dimensional drawing (D)	Wiring diagram (W)	Drive end (S)	Connector (C)	Performance curve (P)
<b>12 V</b>	0 130 822 488	7.8	6	74.5	1	13.7	73:1	No	R	D1	W1	S1	C1	P1
	0 130 822 489	7.8	6	74.5	1	13.7	73:1	No	L	D2	W1	S1	C1	P1
	0 130 822 492	7.8	6	74.5	1	13	73:1	2x	R	D1	W1 + W3	S1	C2	P3
	0 130 822 493	7.8	6	74.5	1	13	73:1	2x	L	D2	W1 + W3	S1	C2	P3
<b>24 V</b>	0 130 822 490	8.2	3	78.5	1	13.7	73:1	No	R	D1	W2	S1	C1	P2
	0 130 822 491	8.2	3	78.5	1	13.7	73:1	No	L	D2	W2	S1	C1	P2
	0 130 822 494	8.2	3	78.5	1	13.7	73:1	2x	R	D1	W3	S1	C2	P2
	0 130 822 495	8.2	3	78.5	1	13.7	73:1	2x	L	D2	W3	S1	C2	P2

\*Gear housing left: L, gear housing right: R

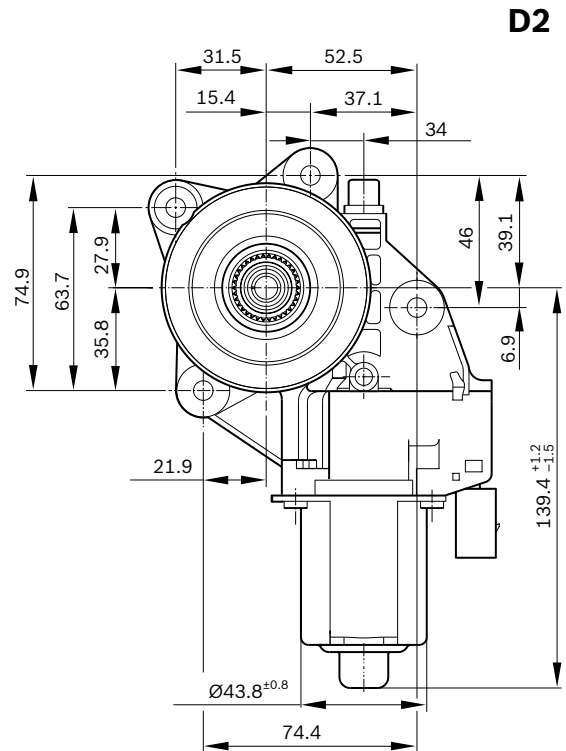
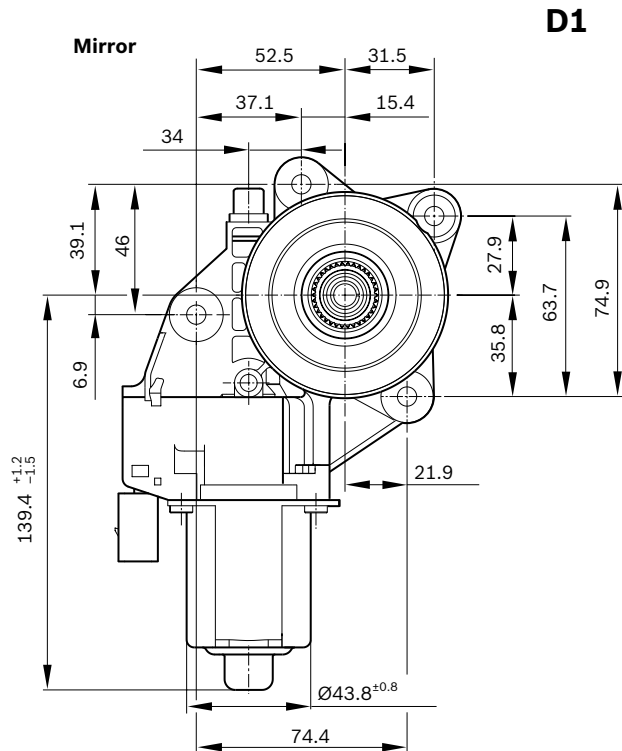

# FPG2

## Wiring diagram (W)

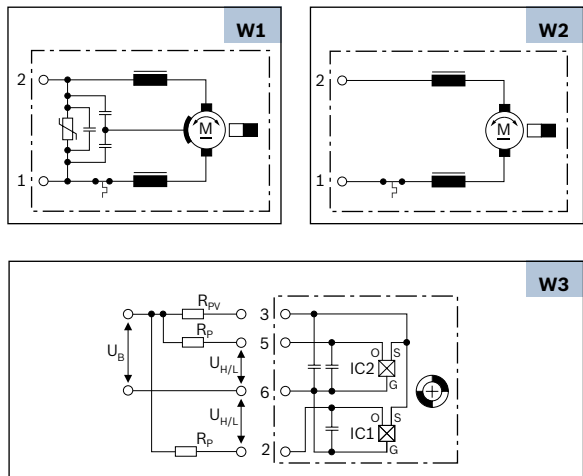

## Performance curve (P)

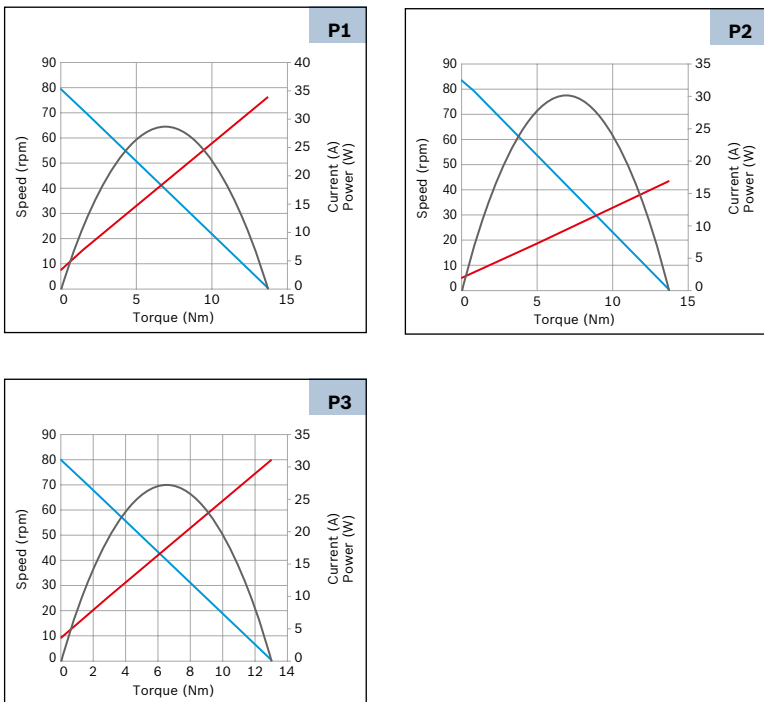

## Drive end (S)

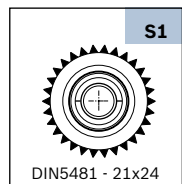

## Mating connector (C)

