

Diese Zeichnung ist unser geistiges Eigentum und darf ohne unsere Erlaubnis weder kopiert, vervielfältigt noch Dritten oder Konkurrenzfirmen zugänglich gemacht werden. (Art. 12 B.G.)
 This drawing is copyright. Information contained therein is supplied in confidence and must not be used for any other purpose than which it was supplied, or be reproduced without written permission of the owners.

32_MMBX-50-0-1

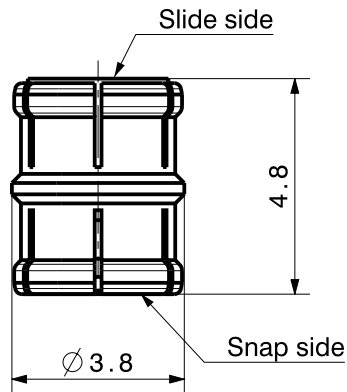

MMBX application instructions are available at www.hubersuhner.com or from your local HUBER+SUHNER sales representative

- 2 If the misalignment between the PCB connectors is bigger then the specified tolerance for the connecting range, a "blind" assembly of the two PCB`s is not longer possible. In this case a manual lead-in is necessary.
- 1 The pull-in range is in relation to the geometry of the PCB connector. Diameter of lead-in.

Pull-in range on PCB connector 1	Connecting range 2	PCB connector with mentioned pull-in range (for example)
1.8	not possible	82 MMBX-S50-0-13
0.95	max. 0.4	only possible in combination with a pull-in range of max. 0.4
0.65	max. 0.1	82 MMBX-S50-0-1

Connecting range

The connecting range is the maximum misalignment which allows a trouble-free connection with the counter PCB (blind mate). (including maximum swiveling angle of adaptor)

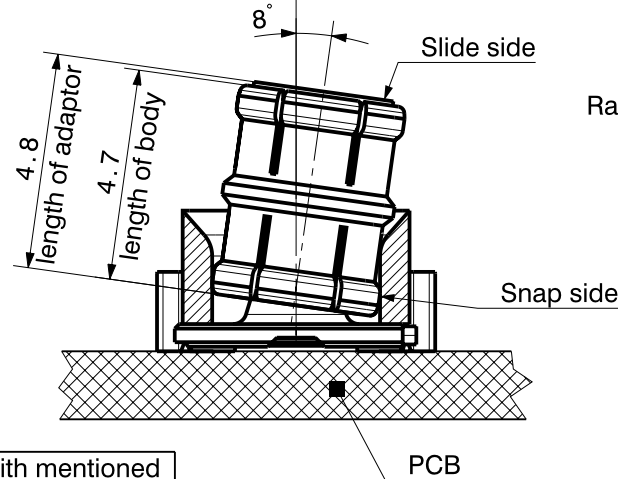
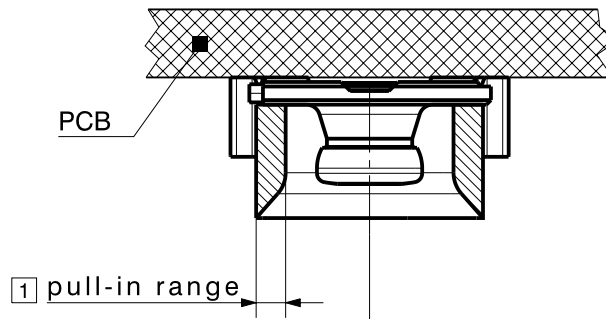

Radial and axial working range

The radial and axial working range is the maximum misalignment that allows a sufficient electrical and mechanical connection.

