

FPG2



Family features:

- ▶ Double-hall sensor available
- ▶ Degree of protection: IP 54
- ▶ Operating mode: S2
- ▶ Direction of rotation: CCW/CW

Voltage	Part number	P _n (Nominal power)	I _n (Nominal current)	n _n (Nominal speed)	M _n (Nominal torque)	M _a (Stall torque)	Gear ratio	Signal	Side*	Dimensional drawing (D)	Wiring diagram (W)	Drive end (S)	Connector (C)	Performance curve (P)
		W	A	rpm	Nm	Nm		Hall						
12 V	0 130 822 488	7.8	6	74.5	1	13.7	73:1	No	R	D1	W1	S1	C1	P1
	0 130 822 489	7.8	6	74.5	1	13.7	73:1	No	L	D2	W1	S1	C1	P1
	0 130 822 492	7.8	6	74.5	1	13	73:1	2x	R	D1	W1 + W3	S1	C2	P3
	0 130 822 493	7.8	6	74.5	1	13	73:1	2x	L	D2	W1 + W3	S1	C2	P3
24 V	0 130 822 494	8.2	3	78.5	1	13.7	73:1	2x	R	D1	W3	S1	C2	P2
	0 130 822 495	8.2	3	78.5	1	13.7	73:1	2x	L	D2	W3	S1	C2	P2

*Gear housing left: L, gear housing right: R

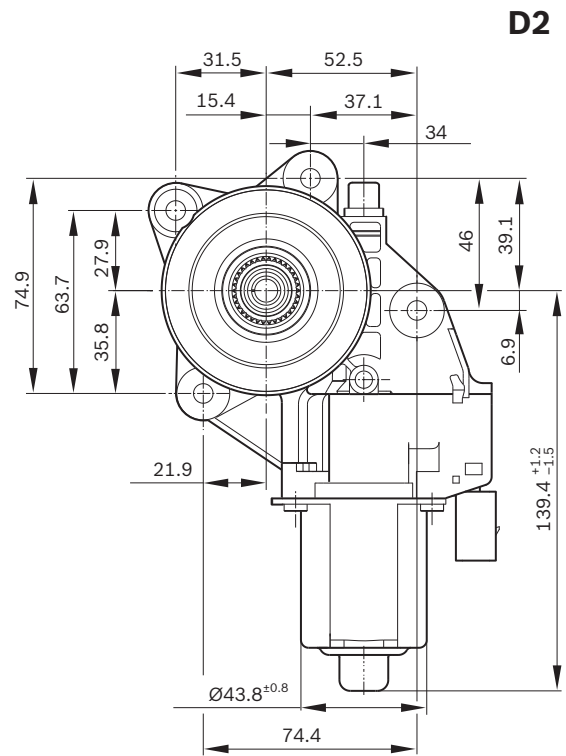
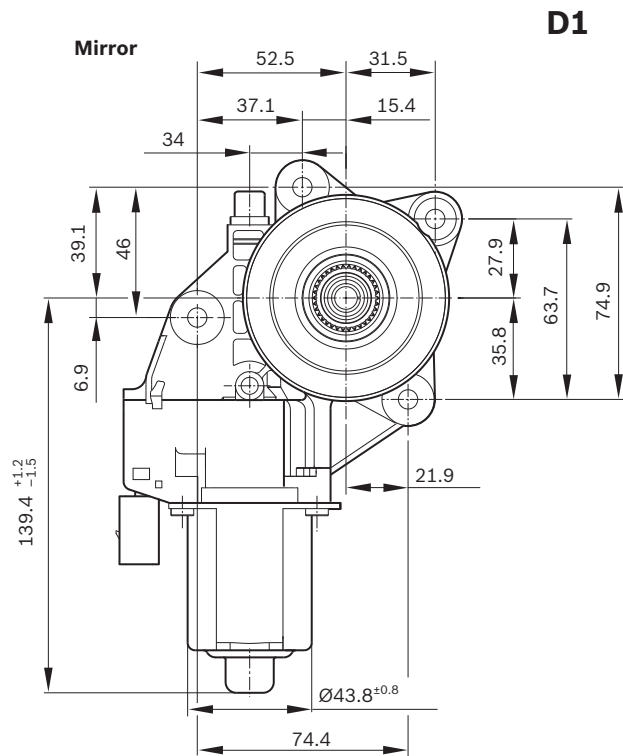

FPG2

Wiring diagram (W)

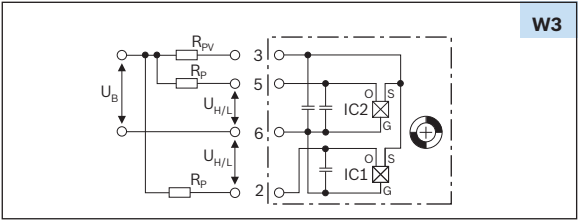
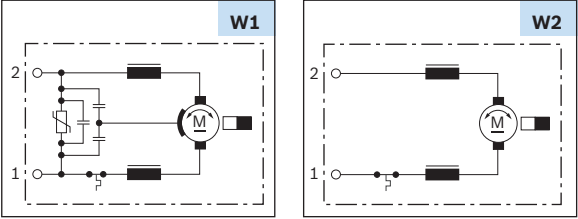

Drive end (S)



Mating connector (C)

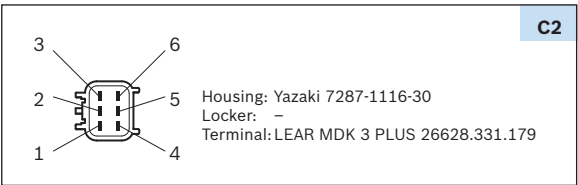
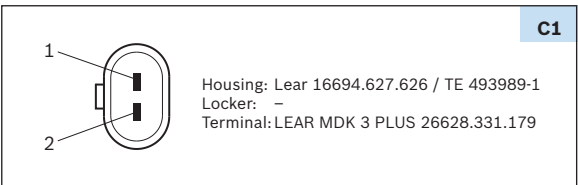

Performance curve (P)

