

GBM-S



Family features:

- ▶ 12 V ventilation module
- ▶ Optimized noise performance
- ▶ High power density
- ▶ Operation mode: S1
- ▶ Degree of protection: IP 13

	Part number	Flow rate	Pressure difference	I _n (Nominal current)	n _n (Nominal speed)	Direction of rotation	Signal	Dimensional drawing (D)	Wiring diagram (W)	Connector (C)	Performance curve (P)
		m ³ /h	Pa	A	rpm		Hall				
12 V	0 130 115 604	400	470	14	4468	CW	No	D1	W1	C1	P1

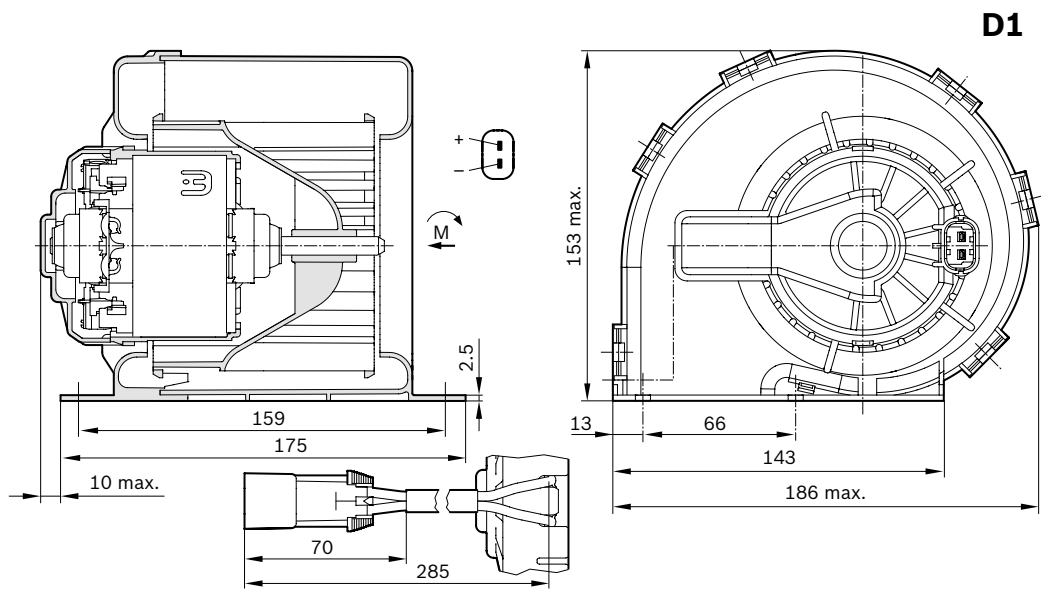

GBM-S

Wiring diagram (W)

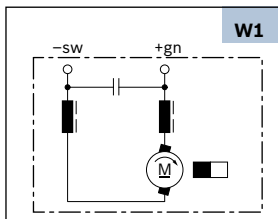

Performance curve (P)

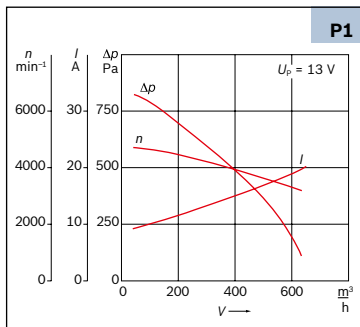

Mating connector (C)

