

| | | | |
|--|----------------------------------|-------------|---------------|
| Entwurfs - Zeichnung DRAFT DRAWING NUMBER | Bestell - Nummer ORDER NUMBER | Typ TYPE | 1 928 A00 451 |
| - | - | - | |

© THIS DRAWING IS THE EXCLUSIVE PROPERTY OF ROBERT BOSCH GMBH. WITHOUT THEIR CONSENT IT MAY NOT BE REPRODUCED OR GIVEN TO THIRD PARTIES.

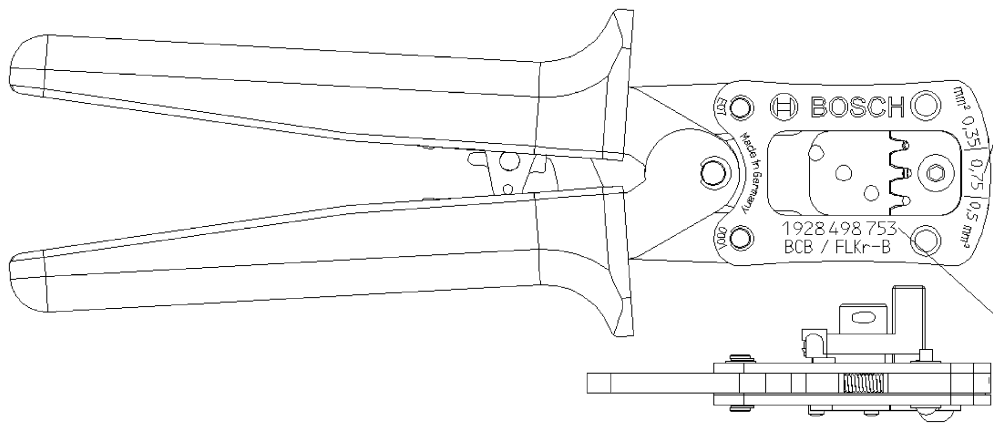

© Alle Rechte bei Robert Bosch GmbH, auch fuer den Fall von Schutzrechtsanmeldungen. Jede Veruegungsbefugnis, wie Kopier- und Weitergaberecht, bei uns.

| | | |
|--------------------------|--|----------------------|
| 1 928 498 753 | 0.75 | 1 928 492 556 |
| | 0.35 / 0.5 | 1 928 492 555 |
| ORDER-NO. Bestell-Nr. | WIRE SIZE Leiterquerschnitt [mm ²] | CONTACTS Kontakte |

Weit. fremdspr. Angebotszeichnungen
FURTHER FOREIGN LANGUAGE OFFER DNGS

| | | | | | | | | |
|----------------------------------|--|---|--|--|-------------------------------|--|-------------------|--|
| - | | Nicht tol. Masse NON TOLERANCED DIMENSIONS | | | Masstab SCALE | | Gewicht WEIGHT | |
| - | | ± - mm, ± - ° | | | Angebots- zeichnung | | OFFER DRAWING | |
| Dokumentenart/ DOCUMENT TYPE AGZ | | | | | Benennung/ TITLE | | | |
| - | | | | | Crimpzange CRIMPING PLIERS | | | |
| - | | | | | Nr./ NO. | | | |
| - | | | | | 1 928 A00 451 | | | |
| - | | | | | de/en | | | |
| - | | | | | Blatt SHEET 1 | | | |
| - | | | | | 1 BI/SH | | | |
| - | | | | | Ers. f. / REPLACES - | | | |
| - | | | | | Ers. d. / REPLAC. BY - | | | |

OBSERVE INSTRUCTIONS FOR FILLING OUT N12A D11/1